

Aerial Work Platforms

Genie® Runabout™ Contractor

Specifications

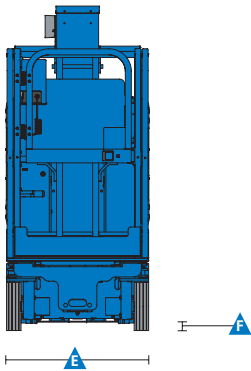
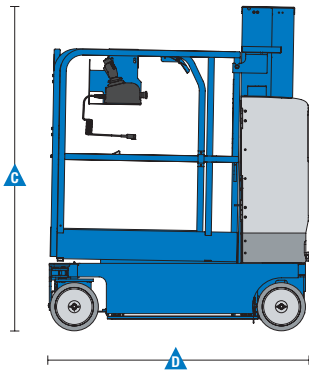
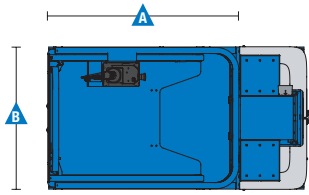

Models	GRC-12	
Measurements	US	Metric
Working height*	18 ft	5.5 m
Platform height	12 ft	3.7 m
A B Platform dimensions (length x width)		
Ext Platform dimensions - retracted	39 x 29.5 in	.99 x .75 m
Ext Platform dimensions - extended	55 x 29.5 in	1.4 x .75 m
C Height - stowed	67 in	1.70 m
D Length - stowed	4 ft 5.75 in	1.37 m
E Width ANSI, CSA	2 ft 5.5 in	.75 m
CE, AUS	2 ft 5.5 in	.75 m
F Ground clearance - center	2.5 in	.06 m

Productivity

Lift capacity	500 lbs	227 kg
Lift capacity - extension deck	250 lbs	113 kg
Drive speed - stowed	2.5 mph	4.0 km/h
Drive speed - raised	0.5 mph	0.8 km/h
Gradeability**	30%	
Turning radius - inside	zero	zero
Turning radius - outside ANSI/CSA	4 ft 4 in	1.32 m
Turning radius - outside AUS/CE	4 ft 5 in	1.35 m
Raise / lower speed	12 / 16 sec	12 / 16 sec
Controls		24V DC proportional
Tires - solid non-marking	10 x 3 x 8 in	25 x 8 x 20 cm

Power

Power source	24V (four 6V 225 Ah batteries)	
Hydraulic system capacity	2.2 gal	8.33 L

Weight***

ANSI, CSA	1,916 lbs	869 kg
CE, AUS	2,090 lbs	948 kg

Standards Compliance

ANSI A92.6, CSA B354.2, CE Compliance, AS 1418.10

* The metric equivalent of working height adds 2 m to platform height. U.S. adds 6 ft to platform height.

** Gradeability applies to driving on slopes. See operator's manual for details regarding slope rating.

*** Weight will vary depending on options and/or country standards.